

SCTE • ISBE[®]

S T A N D A R D S

Interface Practices Subcommittee

AMERICAN NATIONAL STANDARD

ANSI/SCTE 77 2017

Specifications for Underground Enclosure Integrity

NOTICE

The Society of Cable Telecommunications Engineers (SCTE) / International Society of Broadband Experts (ISBE) Standards and Operational Practices (hereafter called “documents”) are intended to serve the public interest by providing specifications, test methods and procedures that promote uniformity of product, interchangeability, best practices and ultimately the long-term reliability of broadband communications facilities. These documents shall not in any way preclude any member or non-member of SCTE•ISBE from manufacturing or selling products not conforming to such documents, nor shall the existence of such standards preclude their voluntary use by those other than SCTE•ISBE members.

SCTE•ISBE assumes no obligations or liability whatsoever to any party who may adopt the documents. Such adopting party assumes all risks associated with adoption of these documents, and accepts full responsibility for any damage and/or claims arising from the adoption of such documents.

Attention is called to the possibility that implementation of this document may require the use of subject matter covered by patent rights. By publication of this document, no position is taken with respect to the existence or validity of any patent rights in connection therewith. SCTE•ISBE shall not be responsible for identifying patents for which a license may be required or for conducting inquiries into the legal validity or scope of those patents that are brought to its attention.

Patent holders who believe that they hold patents which are essential to the implementation of this document have been requested to provide information about those patents and any related licensing terms and conditions. Any such declarations made before or after publication of this document are available on the SCTE•ISBE web site at <http://www.scte.org>.

All Rights Reserved

© Society of Cable Telecommunications Engineers, Inc. 2017
140 Philips Road
Exton, PA 19341

Table of Contents

Title	Page Number
NOTICE _____	2
Table of Contents _____	3
1. Introduction _____	5
1.1. Executive Summary _____	5
1.2. Scope _____	5
1.3. Benefits _____	5
1.4. Intended Audience _____	5
1.5. Areas for Further Investigation or to be Added in Future Versions _____	5
2. Normative References _____	6
2.1. Standards from Other Organizations _____	6
3. Informative References _____	6
3.1. Published Materials _____	6
4. Compliance Notation _____	7
5. Definitions _____	7
5.1. Definitions _____	7
6. Environmental Test _____	7
6.1. Control Coupons _____	7
6.2. Chemical Resistance _____	8
6.3. Simulated Sunlight Exposure _____	8
6.4. Water Absorption _____	8
6.5. Flammability _____	8
6.6. Internal Equipment Protection Test _____	9
7. Structural Load Tests on Full-Size Products _____	9
7.1. Lateral Sidewall Load Test _____	10
7.2. Vertical Sidewall Load Test _____	10
7.3. Cover Vertical Load Test _____	10
7.4. Loading Acceptance Criteria _____	11
7.5. Cover Impact _____	11
7.6. Coefficient of Friction Test _____	11
7.7. Torque Value of Fastening Devices _____	11

List of Figures

Title	Page Number
Figure 1 – Torque Test Setup for Threaded Inserts and Bolts	12
Figure 2 - Cover Vertical Load Test (Pedestrian, Tiers 5, 8, & 15)	13
Figure 3 - Cover Vertical Load Test (Tier 22)	13
Figure 4 - Cover Vertical Load Test for Multiple Covers (Center of Cover) (Pedestrian, Tiers 5, 8, & 15)	14
Figure 5 - Cover Vertical Load Test for Multiple Covers (Center of Partial Cover) (Pedestrian, Tiers 5, 8, & 15)	14
Figure 6 - Cover Vertical Load Test for Multiple Covers (Center of Cover) (Tier 22)	15
Figure 7 - Cover Vertical Load Test for Multiple Covers (Center of Partial Cover) (Tier 22)	15
Figure 8 - Box Vertical Sidewall Load Test (Pedestrian, Tiers 5, 8 & 15)	16
Figure 9 - Box Vertical Sidewall Load Test (Tier 22)	16
Figure 10 - Vertical Sidewall Load Test for Round Enclosures (Pedestrian, Tiers 5, 8, & 15)	17
Figure 11 - Vertical Sidewall Load Test for Round Enclosures (Tier 22)	17
Figure 12 - Box Lateral Sidewall Test for Boxes < 60" Long	18
Figure 13 - Box Lateral Sidewall Test for Boxes ≥ 60" long	18
Figure 14 - Lateral Sidewall Test for Round Enclosures ≥ 24" in Depth	19
Figure 15 - Lateral Sidewall Test for Round Enclosures < 24" in Depth	19

List of Tables

Title	Page Number
Table 1 – Reagent/Concentration in Water	8
Table 2 - Design/Test Loads	9
Table 3 – Maximum Allowable Deflection at Design Load	11
Table 4 – Recommended Torque Values	12

1. Introduction

1.1. Executive Summary

The purpose of this document is to establish the performance requirements for underground enclosures. The document provides Standards Engineers and Systems Designers a means of evaluating underground enclosure performance regardless of the materials used or the methods employed in the manufacture of the enclosures.

1.2. Scope

The scope of this document covers conformance tests and requirements for the integrity of grade-level enclosures containing telecommunication or other low voltage apparatus that *may* be exposed to the public.

The purpose of this document is to describe the requirements for a comprehensive integrity system for grade-level enclosures providing long installation life and minimal maintenance. This document is intended to provide guidance for the use of enclosures in non-deliberate traffic areas. Requirements for enclosures in deliberate traffic areas are covered by American Association of State Highway and Transportation Officials (AASHTO).

1.3. Benefits

Underground enclosures are designed and used for a variety of applications: slack cable, junction enclosures, and splice enclosures, etc. This document provides the specifier and end user the minimum performance criteria needed to ensure that the enclosure is designed for the outside plant application. Without this document there are no performance requirements for outside plant enclosures, and the long term integrity of the system may be compromised. This document helps specifying individuals design the outside plant and establish enclosure performance requirements throughout the system. The document will serve as a method to ensure long term enclosure integrity as more outside plant systems are installed underground.

1.4. Intended Audience

A Standard Engineer or System Designer will be able to use this document to evaluate products from a variety of manufacturers and specify the best product for the application. It is intended to be used by a large cross section of individuals not just those with engineering backgrounds. The test methods and accompanying figures are intended to guide the individual through the process in a logical manner.

1.5. Areas for Further Investigation or to be Added in Future Versions

Areas of future investigation include:

- Adding a section dedicated to installation applications
- Adding a section dedicated to installation details
- Adding a section for hybrid type installations to help others benefit from work being done across the country

2. Normative References

The following documents contain provisions, which, through reference in this text, constitute provisions of the standard. At the time of Subcommittee approval, the editions indicated were valid. All standards are subject to revision; and while parties to any agreement based on this standard are encouraged to investigate the possibility of applying the most recent editions of the documents listed below, they are reminded that newer editions of those documents may not be compatible with the referenced version.

2.1. Standards from Other Organizations

1. ASTM D543-14 “Standard Practices for Evaluating the Resistance of Plastics to Chemical Reagents”
2. ASTM D570-98 (2010) “Standard Test Method for Water Absorption of Plastics”
3. ASTM D635-06 “Standard Test Method for Rate of Burning and/or Extent and Time of Burning Plastics in a Horizontal Position”
4. ASTM D2444-99 (2010) “Standard Test Method for Determination of the Impact Resistance of Thermoplastic Pipe and Fittings by Means of a Tup (Falling Weight)”
5. ASTM G154-12 “Standard Practice for Operating Fluorescent Light Apparatus for UV Exposure of Nonmetallic Materials”
6. US Dept. of Agriculture, Rural Utilities Service, 7 CFR 1755.910 “RUS Specification for Outside Plant Housings and Serving Area Interface Systems”
7. ASTM C1028-07 “Standard Test Method for Determining the Static Coefficient of Friction of Ceramic Tile and Other Like Surfaces by the Horizontal Dynamometer Pull-Meter Method”

3. Informative References

The following documents may provide valuable information to the reader but are not required when complying with this standard.

3.1. Published Materials

1. American Association of State Highway and Transportation Officials (AASHTO) “Standard Specification for Highway Bridges” 17th Edition.
2. National Fire Protection Association (NFPA 70) National Electric Code 2014, Section 314.30
3. Americans with Disabilities Act (ADA) “Accessibility Guidelines for Buildings and Facilities” (ADAAG) and the “Technical Bulletin: Floor and Ground Surfaces”. Both are free from US Government website <http://www.access-board.gov/>.
4. Torque values for UNC threads taken from Audel Mechanical Trades, 4th Edition

4. Compliance Notation

<i>shall</i>	This word or the adjective means that the item is an absolute requirement of this specification.
<i>shall not</i>	This phrase means that the item is an absolute prohibition of this specification.
<i>forbidden</i>	<i>This word means the value specified shall never be used.</i>
<i>should</i>	<i>This word or the adjective “recommended” means that there may exist valid reasons in particular circumstances to ignore this item, but the full implications should be understood and the case carefully weighted before choosing a different course.</i>
<i>should not</i>	<i>This phrase means that there may exist valid reasons in particular circumstances when the listed behavior is acceptable or even useful, but the full implications should be understood and the case carefully weighed before implementing any behavior described with this label.</i>
<i>may</i>	<i>This word or the adjective “optional” means that this item is truly optional. One vendor may choose to include the item because a particular marketplace requires it or because it enhances the product, for example; another vendor may omit the same item.</i>
<i>deprecated</i>	<i>Use is permissible for legacy purposes only. Deprecated features may be removed from future versions of the standard. Implementations should avoid use of deprecated features.</i>

5. Definitions

5.1. Definitions

Underground Enclosure	An enclosure which houses and protects underground distribution equipment, including but not limited to: splice cases, excess cable, and construction or pull-box equipment. These enclosures are typically non-metallic. The removable cover is typically installed flush to grade and supports the anticipated loading requirements of the installation.
Failure Load	The inability of the product to accept any further increase in load
Design Load	The intended service load of the enclosure
Test Load	The design load multiplied by a safety factor.

6. Environmental Test

Note: Forty-eight (48) material coupons are required to complete the environmental tests.

6.1. Control Coupons

Six (6) coupons of the enclosure material(s) *shall* be prepared. The thickness *shall* match the material thickness of the appropriate section of the enclosure. The length and width *shall* be determined by the testing equipment to be used. These coupons are the control coupons. Test the coupons for ultimate flexural strength. Average the values of stress and deflection at failure for each coupon to establish the control values.

6.2. Chemical Resistance

Thirty (30) material coupons with the same dimensions as the control coupons *shall* be measured and weighed, and three coupons exposed to each of the following chemical reagents:

Table 1 – Reagent/Concentration in Water

Reagent	Concentration in water solution
Sodium Chloride	5%
Sulfuric Acid	0.1N
Sodium Carbonate	0.1N
Sodium Sulfate	0.1N
Hydrochloric Acid	0.2N
Sodium Hydroxide	0.1N
Acetic Acid	5%
Kerosene	Per ASTM D3699, Type K1
Transformer Oil	Per ASTM D3487, Type II
Magnesium Chloride	5%

Expose the coupons in accordance with ASTM D543, Immersion Test, Practice “A”, Procedures 1 and 2, with both conducted at room temperature, using Standard Laboratory Atmosphere and seven days for all tests. After exposure, measure, weigh and visually examine the coupons for changes. Test the coupons for ultimate flexural strength. Average the values of stress and deflection at failure for each coupon to establish the values for each reagent. The tested coupons *shall* retain at least 75% of the control values for stress and deflection and have no more than a 2% change in weight.

6.3. Simulated Sunlight Exposure

Three (3) material coupons with the same dimensions as the control coupons *shall* be measured, weighed, and tested in accordance with ASTM G154 per Cycle #1 of Appendix X2 for 1000 hours to simulate direct solar UV radiation. After exposure, measure, weigh and visually examine the coupons for changes. Test the coupons for ultimate flexural strength. Average the values of stress and deflection at failure for each coupon to establish the test values. The tested coupons *shall* retain at least 75% of the control values for stress and deflection and have no more than a 2% change in weight.

6.4. Water Absorption

Six (6) material coupons, three (3) for the twenty-four-hour test and three (3) for the boil test, with the same dimensions as the control coupons *shall* be measured, weighed, and tested in accordance with ASTM D570, sections 6, 7.1, and 7.5. After exposure, measure, weigh and visually examine the coupons for changes. Test the coupons for ultimate flexural strength. Average the values of stress and deflection at failure for each coupon to establish the test values. The tested coupons *shall* retain at least 75% of the control values for stress and deflection and have no more than a 2% change in weight.

6.5. Flammability

Three (3) material coupons with dimensions 25mm (1 inch) wide by 125mm (5 inch) long by finished product thickness are held in a horizontal position, ignited on one end, and the rate of burning along the length determined in accordance with ASTM D635, Sections 4, 5 and 6. The burning rate *shall* be less than 8mm (0.3 inch) per minute for each 3mm (0.1 inch) of thickness.

6.6 Internal Equipment Protection Test

The enclosure and the internal equipment therein *shall* remain suitable for use when tested for fire resistance in accordance with US Dept. of Agriculture, Rural Utilities Service, 7 CFR 1755.910 Section (e) “Performance Criteria and Test Procedures for Housings”, subsection (3) “Environmental Requirement for Housings”, paragraph xiii, “Fire Resistance”, requirement (A).

The test housing *shall* be installed in a manner typical of field installation. U.S. No. 1 wheat straw *shall* be placed on the ground around the housing base in an one meter (3 ft) radius at an approximate depth of 10 cm (4 in.). The straw *shall* be ignited and permitted to burn fully. After the housing has cooled, its contents *shall* be inspected for evidence of ignition, melting, burning, or structural damage. Damage sufficient to impair service constitutes failure.

7. Structural Load Tests on Full-Size Products

It is recognized that as wheels roll over an enclosure, loads are imparted laterally and vertically into the sidewall, and vertically onto the cover. The structural load tests *shall* use the three test positions as described in paragraphs 7.1 through 7.3 to evaluate enclosures and match the intended application with enclosure performance: Figure 2, Figure 4, Figure 5, Figure 8 and Figure 10 for all Tiers up to and including Tier 15; Figure 3, Figure 6, Figure 7, Figure 9 and Figure 11 for Tier 22; Figure 12, Figure 13, Figure 14 and Figure 15 for the Lateral Sidewall Test for the enclosures. Enclosures *should* be 72 +/- 8 °F when tested. See Table 2 for the Load Requirements for all Tiers.

Table 2 - Design/Test Loads

Application	Loading Requirements			
Light Duty Pedestrian Traffic Only	Vertical	Test Load	13.3kN	3000 pounds
Tier 5 Sidewalk applications with a safety factor for occasional non-deliberate vehicular traffic	Vertical	Design Load	22.2 kN	5000 pounds
		Test Load	33.3 kN	7500 pounds
	Lateral	Design Load	28.7 kPa	1800 pounds.
		Test Load	43.1 kPa	2700 pounds.
Tier 8 Sidewalk applications with a safety factor for non-deliberate vehicular traffic	Vertical	Design Load	35.6 kN	8000 pounds
		Test Load	53.4 kN	12000 pounds
	Lateral	Design Load	28.7 kPa	1800 pounds
		Test Load	43.1 kPa	2700 pounds
Tier 15 Driveway, parking lot, and off-roadway applications subject to occasional non-deliberate heavy vehicular traffic	Vertical	Design Load	66.7 kN	15000 pounds
		Test Load	100.1 kN	22500 pounds
	Lateral	Design Load	38.3 kPa	2400 pounds
		Test Load	57.5 kPa	3600 pounds
Tier 22 Driveway, parking lot, and off-roadway applications subject to occasional non-deliberate heavy vehicular traffic	Vertical	Design Load	100.1 kN	22500 pounds
		Test Load	150.1 kN	33750 pounds
	Lateral	Design Load	38.3 kPa	2400 pounds
		Test Load	57.5 kPa	3600 pounds
AASHTO H-20 Deliberate vehicular traffic applications.	Certified precast concrete, cast iron, or AASHTO-recognized materials.			

7.1. Lateral Sidewall Load Test

Apply the uniformly distributed lateral load parallel to the top surface of the enclosure on the longest wall as shown in of Figure 12, Figure 13, Figure 14 and Figure 15. Transmit the load using a flat, rigid steel plate(s) 610mm (24 inch) x 457mm (18 inch) x 25mm (1 inch), yielding a surface area of 3 ft², bearing against any suitable medium which will conform to the shape and angle of the enclosure sidewall (such as sand bags) to achieve uniform load. For enclosures with a long wall dimension less than 1524mm (60 inches), a single loading plate 24 inch wide x 18 inch x 1 inch thick is centered on the sidewall as shown in Figure 12, Figure 14 and Figure 15. For enclosures with a long wall dimension 1524mm (60 inches) or greater, two loading plates 24 inch deep x 18 inch wide x 1 inch thick are used, and the loading plates are located at the L/3 positions and centered vertically as shown in Figure 13. Apply the design load listed in Table 2 to each of the plates. For all lengths of enclosures, support the opposite sidewall in a like manner to achieve a uniform reaction, or support the enclosure on ribs or stiffeners so that no local failure occurs. Use a spherical swivel head in the testing machine. Install a typical cover during this test. Position a deflection measuring device to measure the relative deflection between the testing machine table and the inside center of the loaded sidewall of the enclosure. If a compressible medium is used for a reaction base, its deflection is measured and subtracted from the total to yield the net deflection. Zero the deflection gauge prior to the application of the first design load, and do not re-zero the gauge between cycles. Load the enclosure ten times to design load and record the corresponding deflections for each cycle. Load the enclosure to the test load, or failure, whichever occurs first.

7.2. Vertical Sidewall Load Test

For Tiers up to and including Tier 15, distribute the load over a 127mm (5 inch) x 254mm (10 inch) area (see Figure 8 and Figure 10). Position a 254mm (10 inch) x 254mm (10 inch) x 25mm (1 inch) thick steel load plate over a 13mm (1/2 inch) thick rubber pad so that a 127mm (5 inch) x 254mm (10 inch) area is effective in transferring the load. Center the ram on the 127mm (5 inch) x 254mm (10 inch) area. For Tier 22, distribute the loads over a 127mm (5 inch) x 508mm (20 inch) area (see Figure 9 and 11). Position a 254mm (10 inch) x 508mm (20 inch) x 25mm (1 inch) thick steel load plate over a 13mm (1/2 inch) thick rubber pad so that a 127mm (5 inch) x 508mm (20 inch) area is effective in transferring the load. Center the ram on the 127mm (5 inch) x 508mm (20 inch) area. For all Tiers, support the base with rigid material. The loading pad is centered on the long dimension and performed with a typical cover in-place. Position the deflection measuring devices to indicate both the vertical deflection of the load plate, and the lateral deflection of the center of the wall below the load plate. Zero the deflection gauge prior to the application of the first design load, and do not re-zero the gauge between cycles. Load the enclosure ten times to the design load and record the corresponding deflections for each cycle. Load the enclosure to the test load, or failure, whichever occurs first.

7.3. Cover Vertical Load Test

For Tiers up to and including Tier 15, distribute the vertical load over a 254mm (10 inch) x 254mm (10 inch) area (see Figure 2, Figure 4 and Figure 5). Apply the load with a 254mm (10 inch) x 254mm (10 inch) x 25mm (1 inch) thick steel load plate backed with a 13mm (1/2 inch) thick rubber shim. For Tier 22, distribute the vertical load over a 254mm (10 inch) x 508mm (20 inch) area (see Figure 3, Figure 6 and Figure 7). Apply the load with a 254mm (10 inch) x 508mm (20 inch) x 25mm (1 inch) thick steel load plate backed with a 13mm (1/2 inch) thick rubber shim. For all Tiers, use a spherical bearing swivel head in the testing machine. Install a cover in an enclosure during the test. Center the loading pad over the portion of the cover which will produce the maximum deflection under load. Test Multiple-piece covers on both on the center of the cover and on the center of the partial cover. Measure deflection of the load plate perpendicular to the cover on the long centerline of the enclosure. Zero the deflection gauge prior to the application of the first design load, and do not re-zero the gauge between cycles. Position deflection

measuring device or devices so as to measure only the deflection of the cover. Load the cover ten times to the design load and record the deflection for each cycle. Load the cover to the test load, or failure, whichever occurs first.

7.4. Loading Acceptance Criteria

Failure of any enclosure component *shall not* occur at less than the tabulated test load based on the test conducted and the application. The maximum allowable deflection at the Design Load is indicated in Table 3. For tapered enclosures, use average outside wall length (excluding ribs) to determine maximum allowable lateral deflection. For round enclosures with a tapered wall, use the average outside diameter (excluding ribs) as the wall length. For round enclosures with a straight wall, use the outside diameter (excluding ribs) as the wall length.

Table 3 – Maximum Allowable Deflection at Design Load

Structural Load Test	Maximum Vertical Deflection at Design Load	Maximum Lateral Deflection at Design Load
Lateral Sidewall load Test	N/A	21mm per meter (0.25 inches per foot) of average wall length
Vertical Sidewall Load Test	13mm (0.5 inch)	21mm per meter (0.25 inches per foot) of average wall length
Cover Vertical Load Test	13mm (0.5 inch)	N/A

7.5. Cover Impact

Any exposed portion of the cover *shall* withstand a 95 Nm (70 foot pound) impact administered by a weight having a “C” tup per ASTM D2444 without puncturing or splitting. The test is conducted with the cover on a flat rigid surface such as concrete or steel plate.

7.6. Coefficient of Friction Test

A typical production cover is tested to assess the slip resistance of the walking surface that is or *may* be exposed to pedestrian traffic. The static coefficient of friction of this surface *shall* be a minimum of 0.50 as determined using ASTM 1028-06 Section 8, or any equivalent test method. Other test methods are described in Reference 2.1.

7.7. Torque Value of Fastening Devices

A typical enclosure has threaded inserts in the box with a bolt that fastens the cover to the box. The torque value of the threaded insert and bolt is based on the thread size. Table 4 shows the recommended design and test torque value of the standard inserts and bolts in use. A typical bolt and insert is tested to determine if it will meet the torque value. Thread the bolt into the insert through a steel plate on the bearing ledge of the box, as shown in Figure 1. Tighten the bolt to the test torque value and then remove the bolt from the insert. Failure of a bolt or insert is the inability to remove the bolt by hand from the insert after the load has been released. The box *should not* show any detrimental effects such as cracking, splitting or spalling.

Table 4 – Recommended Torque Values

Thread Size	Grade 2		Grade 5		Grade 8	
	Design	Test	Design	Test	Design	Test
3/8-16 UNC	20 Nm (15 ft lbs)	31 Nm (23 ft lbs)	34 Nm (25 ft lbs)	52 Nm (38 ft lbs)	50 Nm (37 ft lbs)	76 Nm (56 ft lbs)
1/2-13 UNC	50 Nm (37 ft lbs)	76 Nm (56 ft lbs)	81 Nm (60 ft lbs)	122 Nm (90 ft lbs)	125 Nm (92 ft lbs)	187 Nm (138 ft lbs)
5/8-11 UNC	100 Nm (74 ft lbs)	150 Nm (111 ft lbs)	163 Nm (120 ft lbs)	244 Nm (180 ft lbs)	244 Nm (180 ft lbs)	366 Nm (270 ft lbs)
3/8-7 lag thread	20 Nm (15 ft lbs)	31 Nm (23 ft lbs)	N/A		N/A	
1/2-6 lag or coil thread	50 Nm (37 ft lbs)	76 Nm (56 ft lbs)	N/A		N/A	

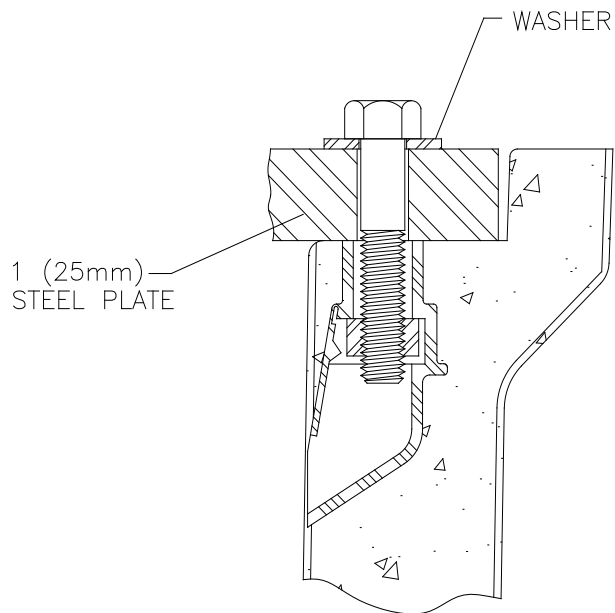
**Figure 1 – Torque Test Setup for Threaded Inserts and Bolts**

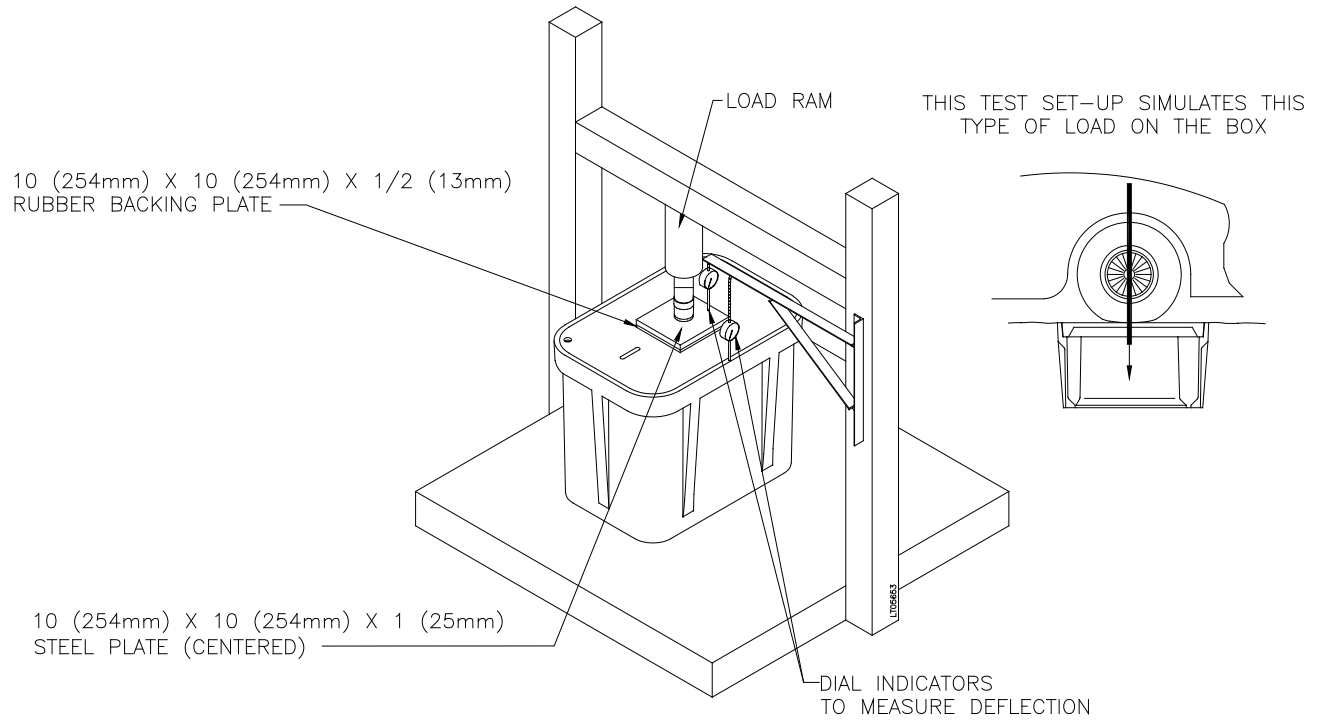

Figure 2 - Cover Vertical Load Test (Pedestrian, Tiers 5, 8, & 15)

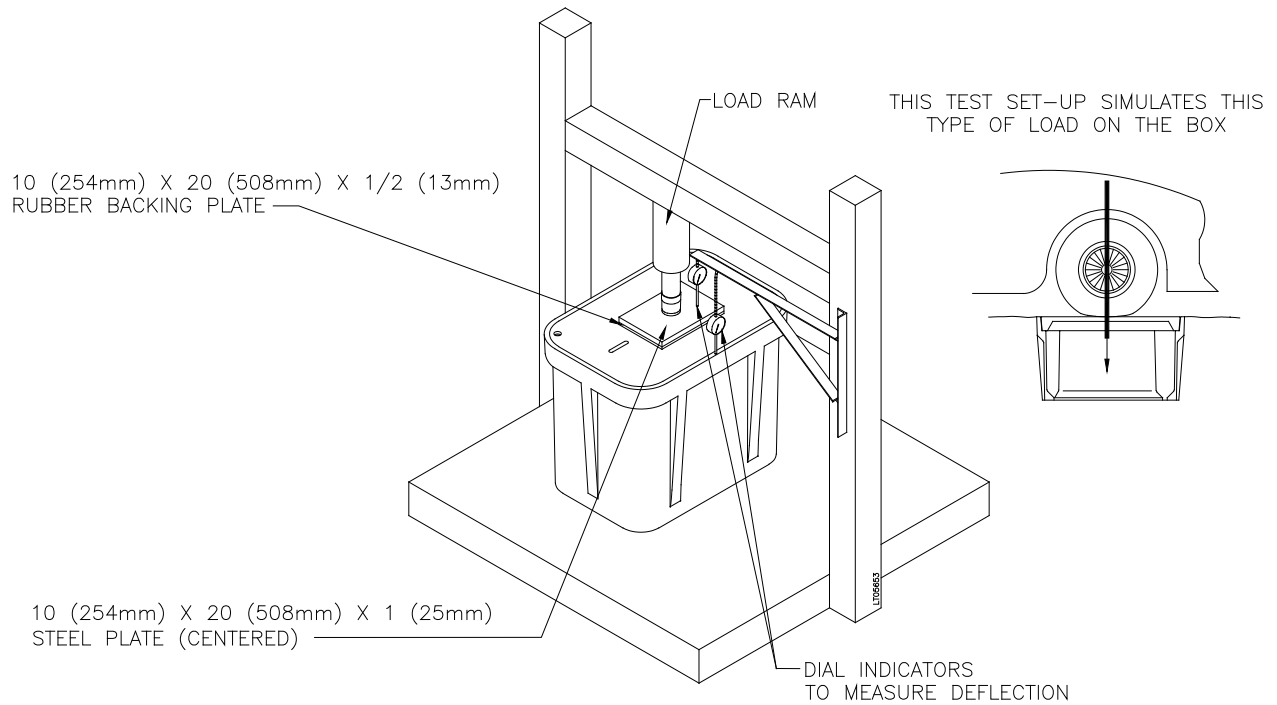

Figure 3 - Cover Vertical Load Test (Tier 22)

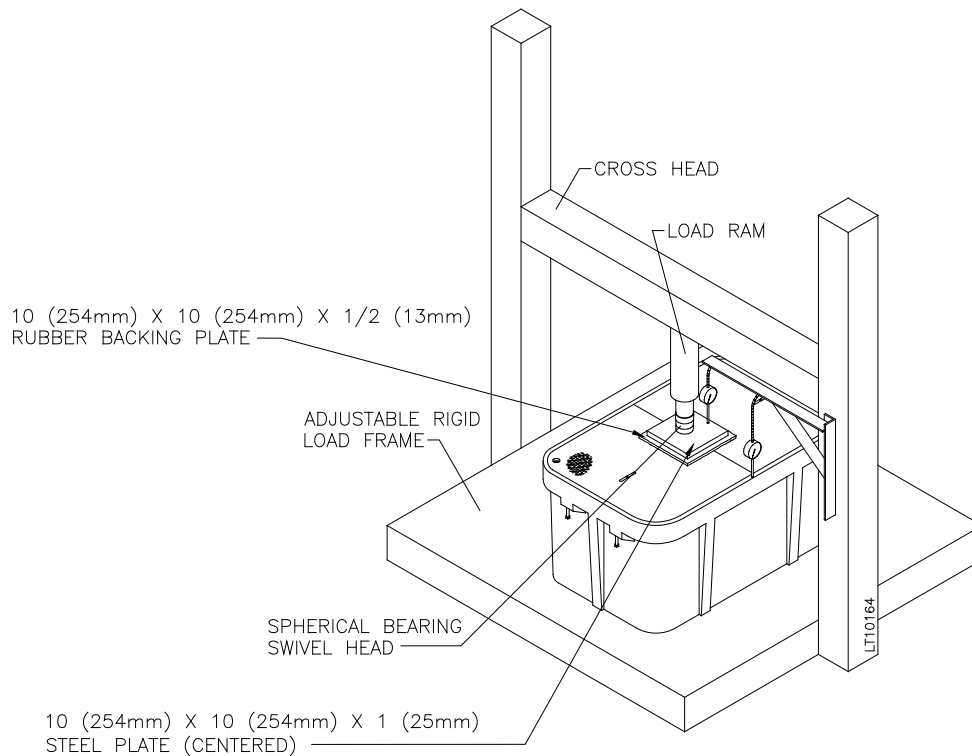

Figure 4 - Cover Vertical Load Test for Multiple Covers (Center of Cover) (Pedestrian, Tiers 5, 8, & 15)

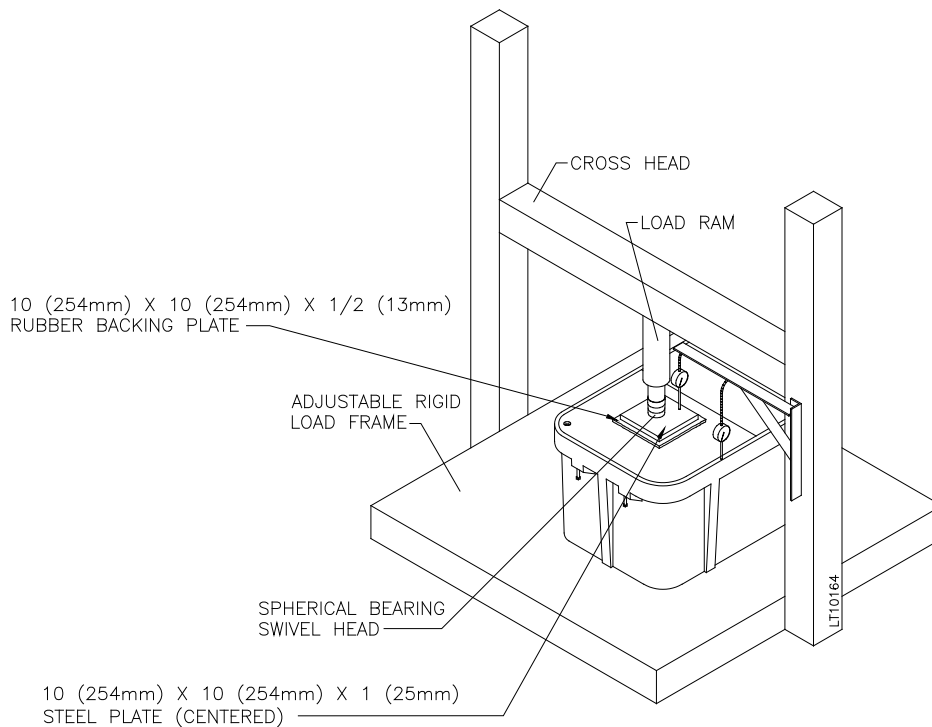

Figure 5 - Cover Vertical Load Test for Multiple Covers (Center of Partial Cover) (Pedestrian, Tiers 5, 8, & 15)

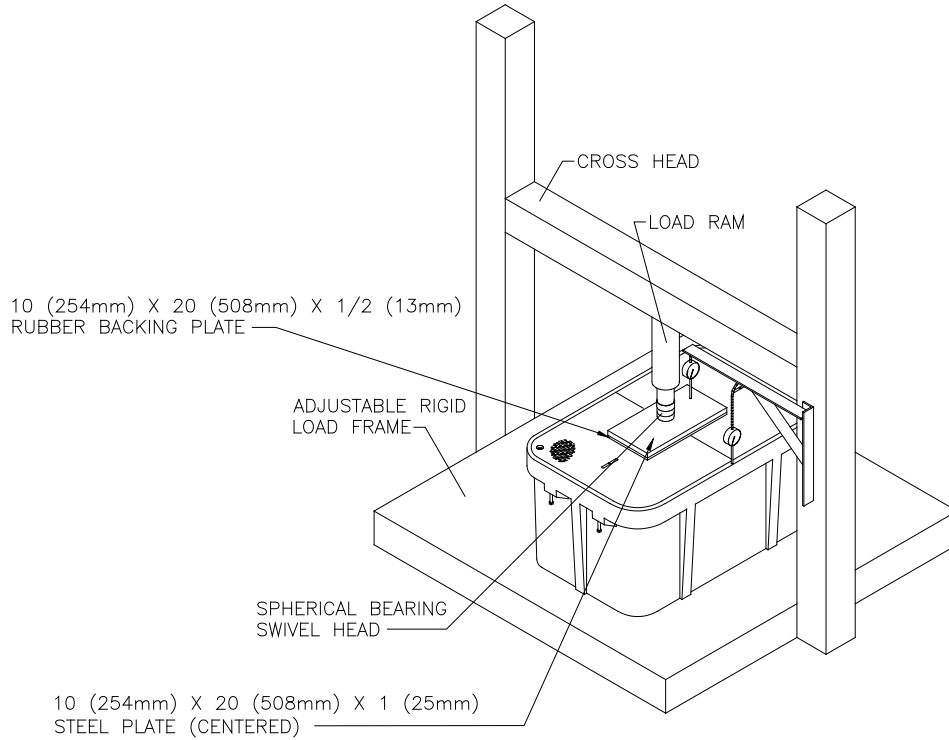

Figure 6 - Cover Vertical Load Test for Multiple Covers (Center of Cover) (Tier 22)

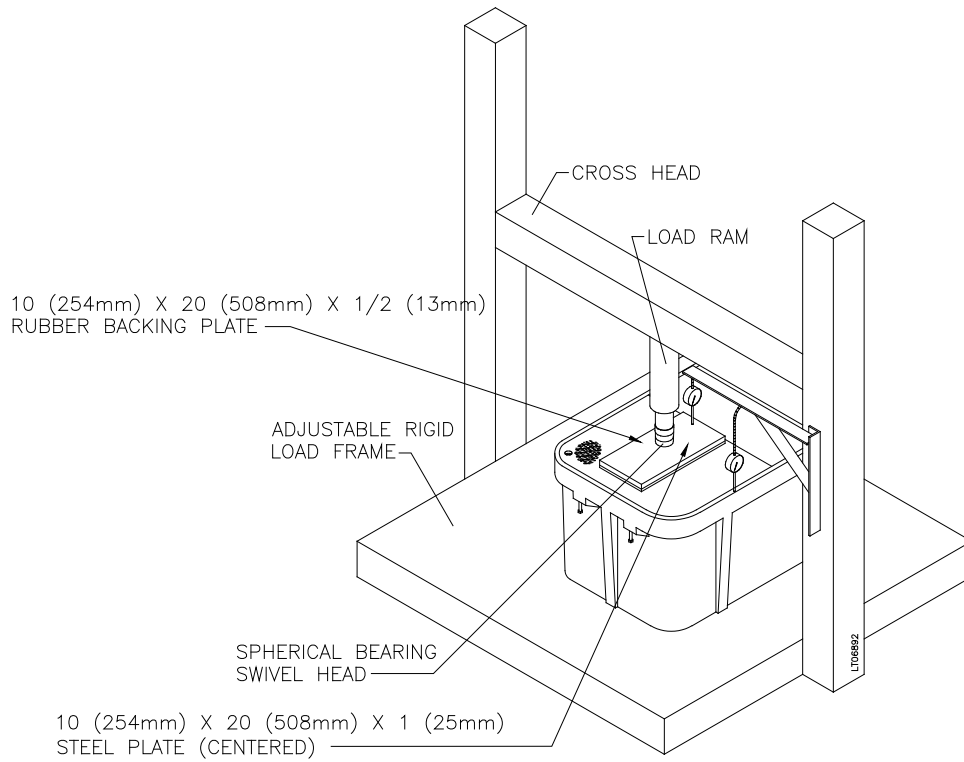

Figure 7 - Cover Vertical Load Test for Multiple Covers (Center of Partial Cover) (Tier 22)

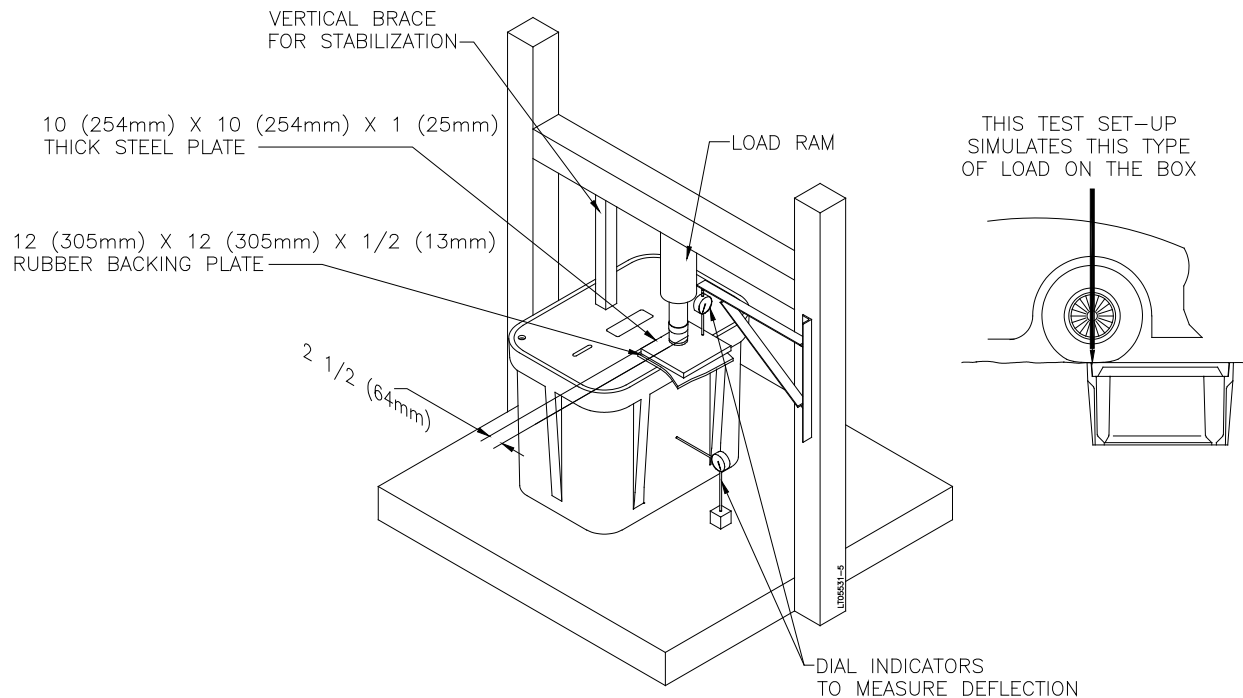

Figure 8 - Box Vertical Sidewall Load Test (Pedestrian, Tiers 5, 8 & 15)

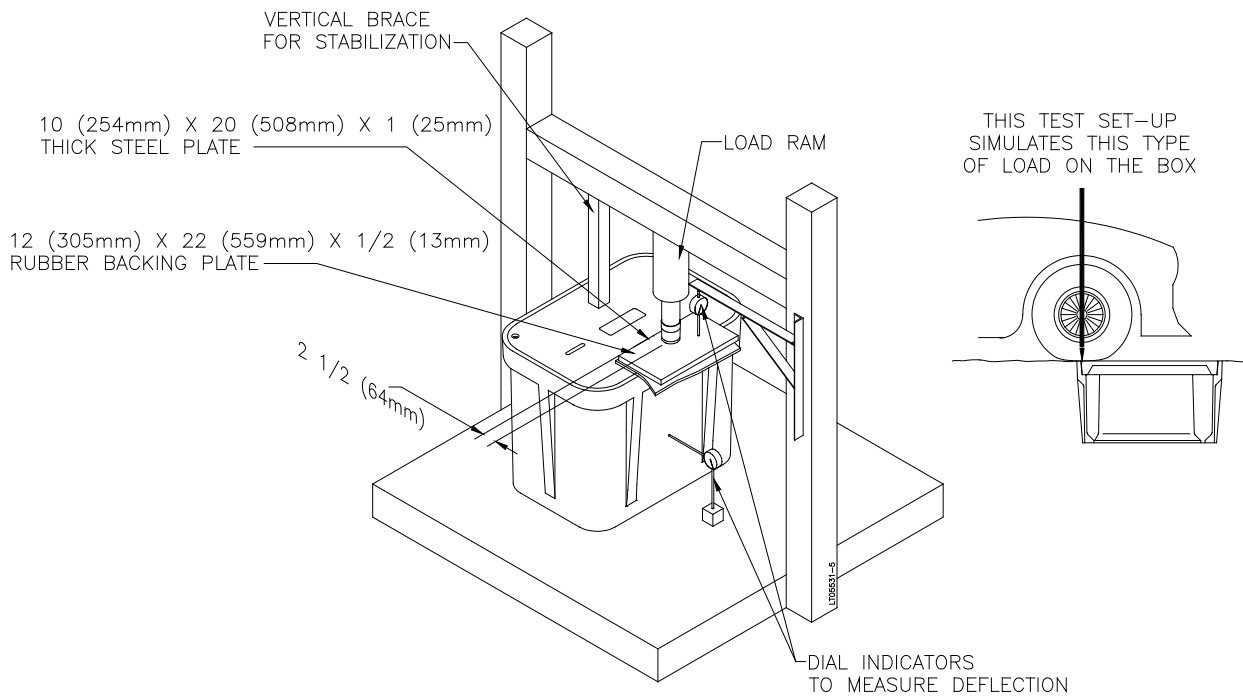

Figure 9 - Box Vertical Sidewall Load Test (Tier 22)

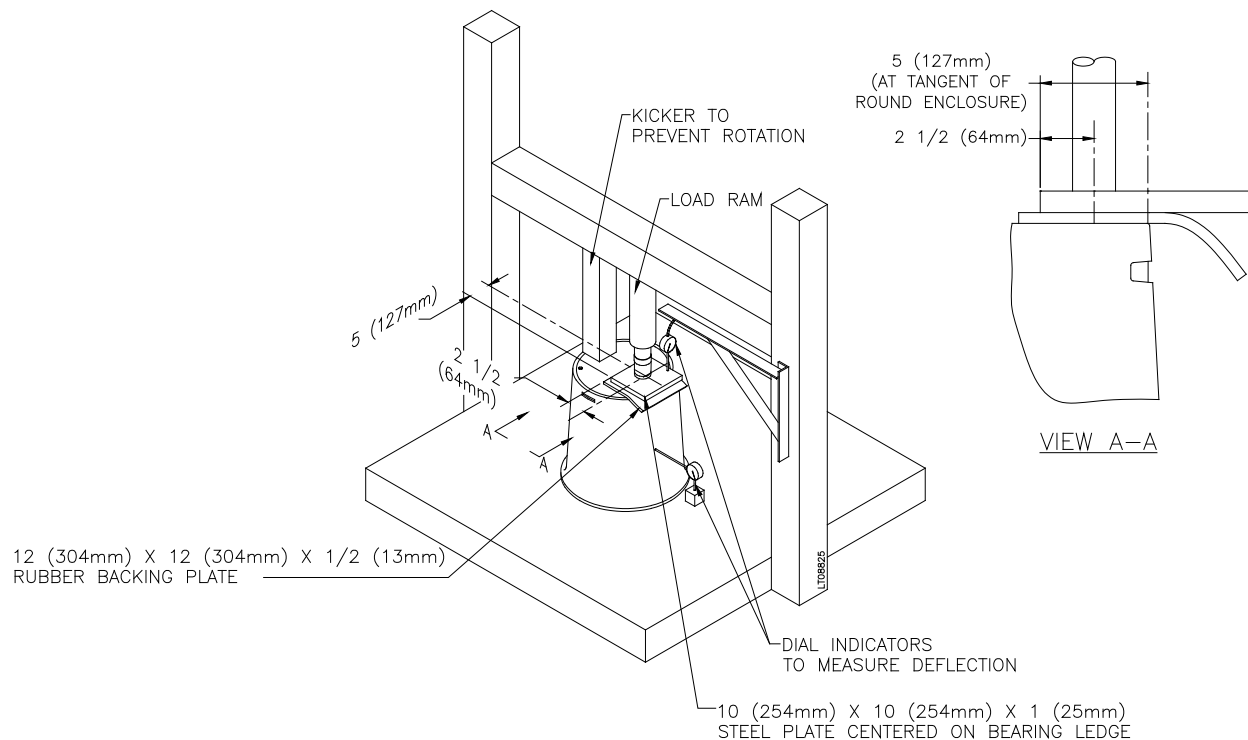

Figure 10 - Vertical Sidewall Load Test for Round Enclosures (Pedestrian, Tiers 5, 8, & 15)

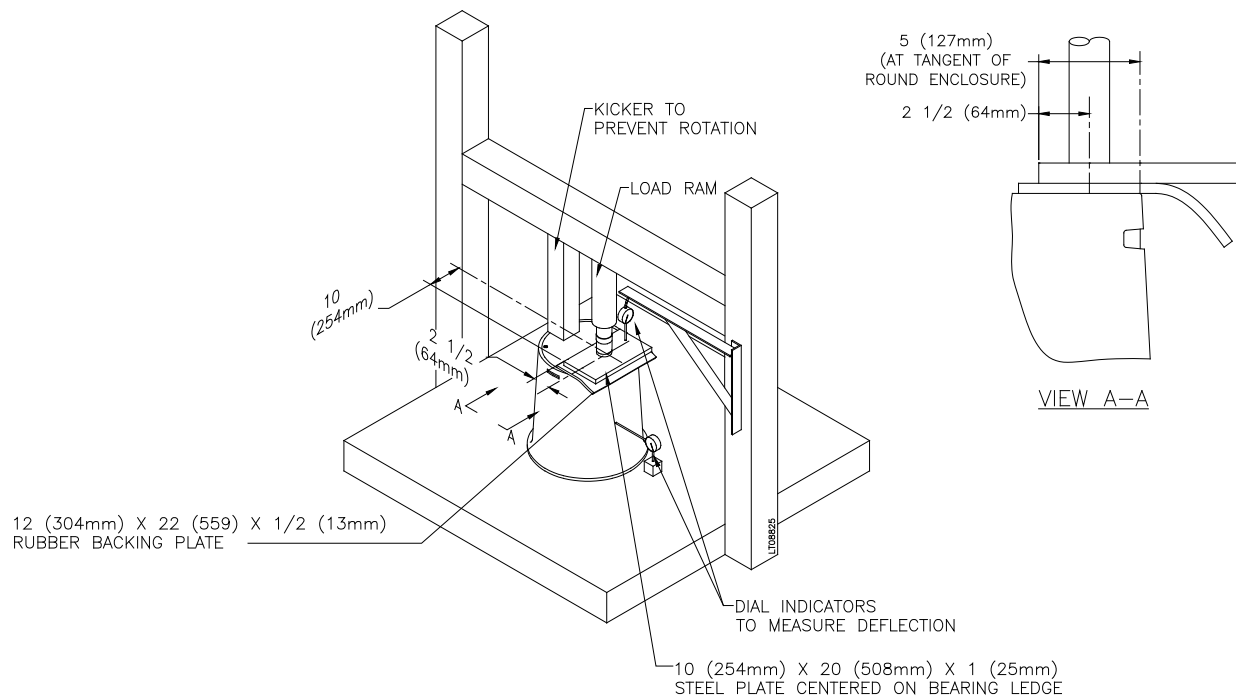

Figure 11 - Vertical Sidewall Load Test for Round Enclosures (Tier 22)

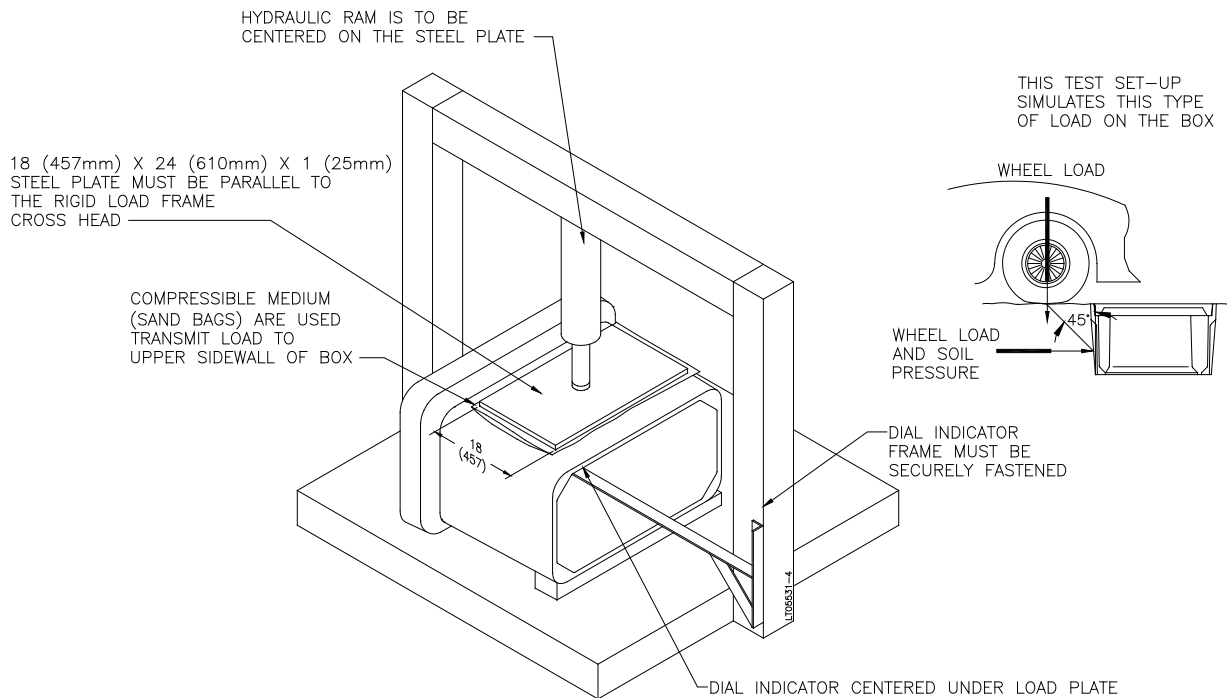

Figure 12 - Box Lateral Sidewall Test for Boxes < 60" Long

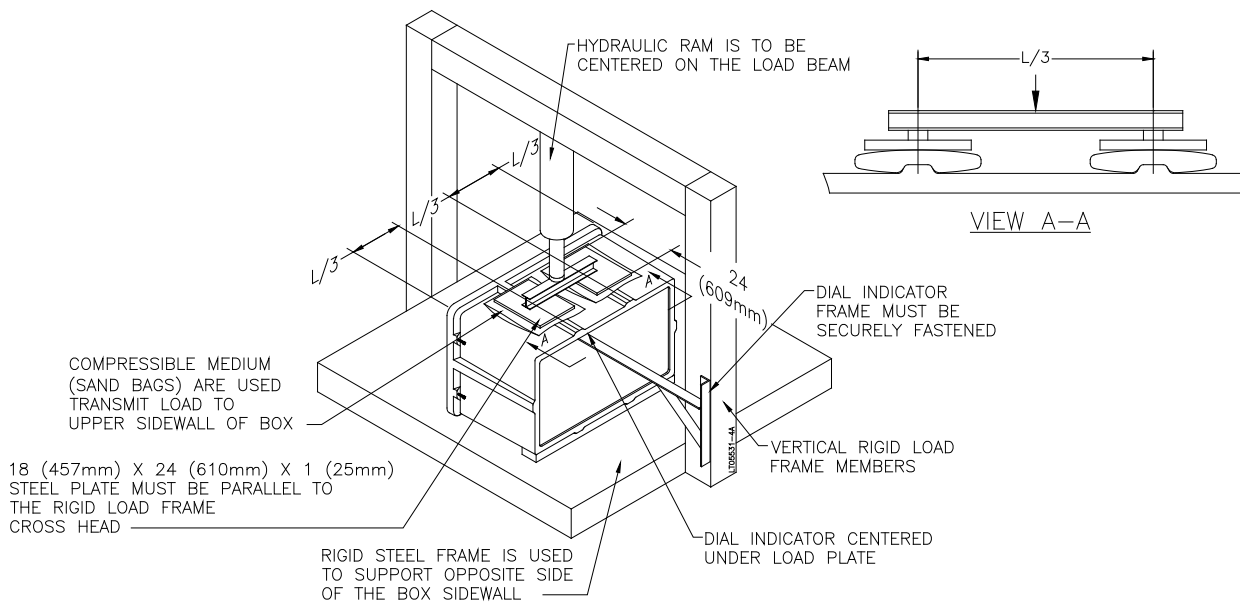

Figure 13 - Box Lateral Sidewall Test for Boxes ≥ 60" long

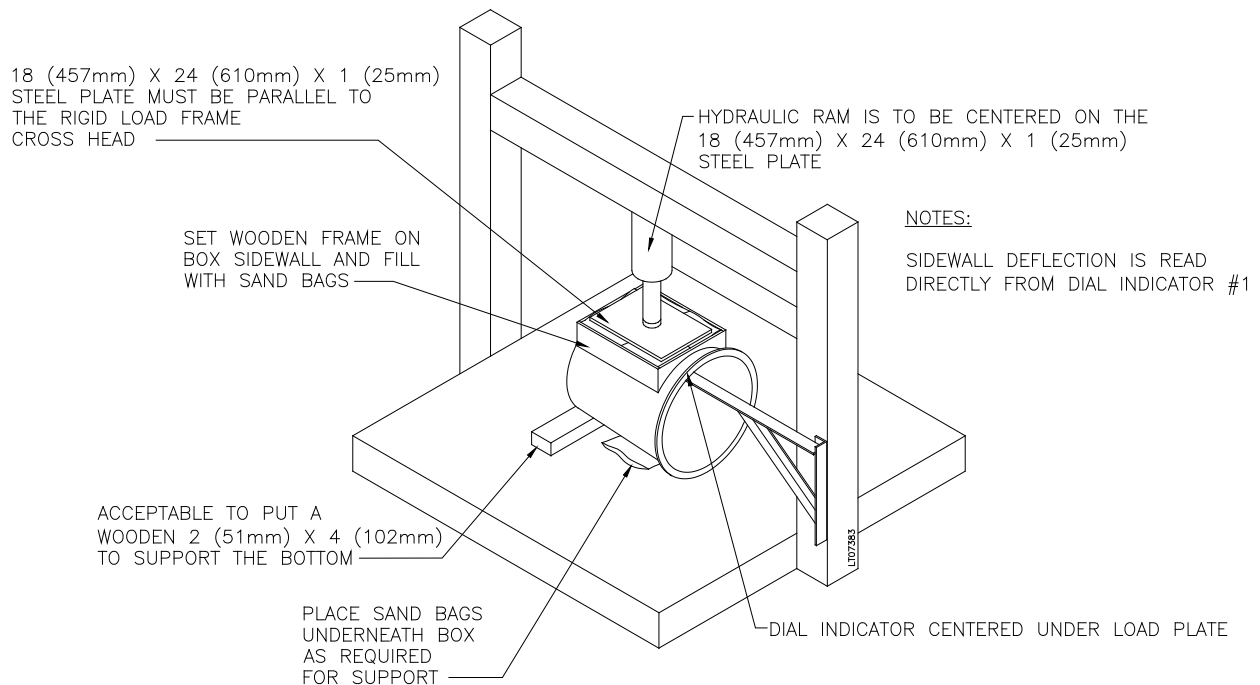

Figure 14 - Lateral Sidewall Test for Round Enclosures \geq 24" in Depth

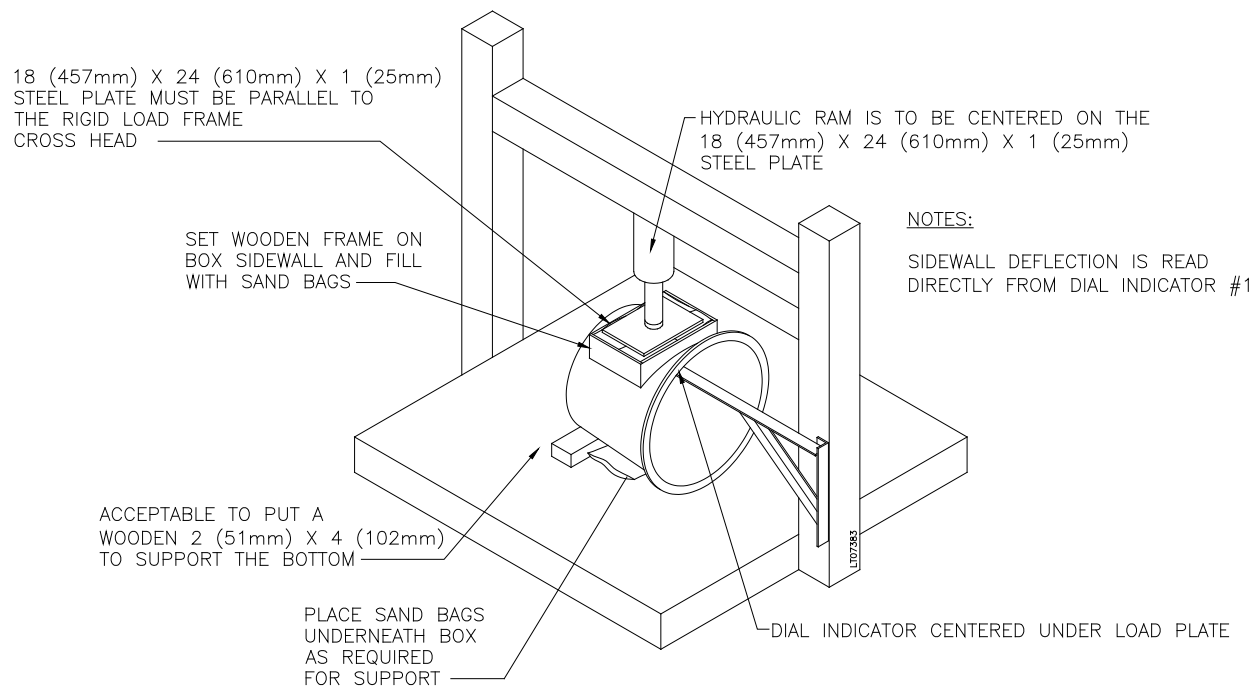

Figure 15 - Lateral Sidewall Test for Round Enclosures $<$ 24" in Depth